

FIT[®]/0...

Digital load cell for
dynamical weighing



Special features

- 4 limit switches with hysteresis
- Dosing functionalities with diagnostic channel (Type E)
- High overload limits
- Degree of protection IP67
- Fast triggering and scaling of the measured value
- Trigger function (external or level trigger)
- Test report for 3000 d accord. to OIML R 60, R 76 in preparation

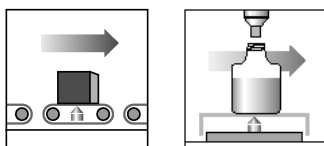

Dimensions (in mm; 1 mm = 0.03937 inches)

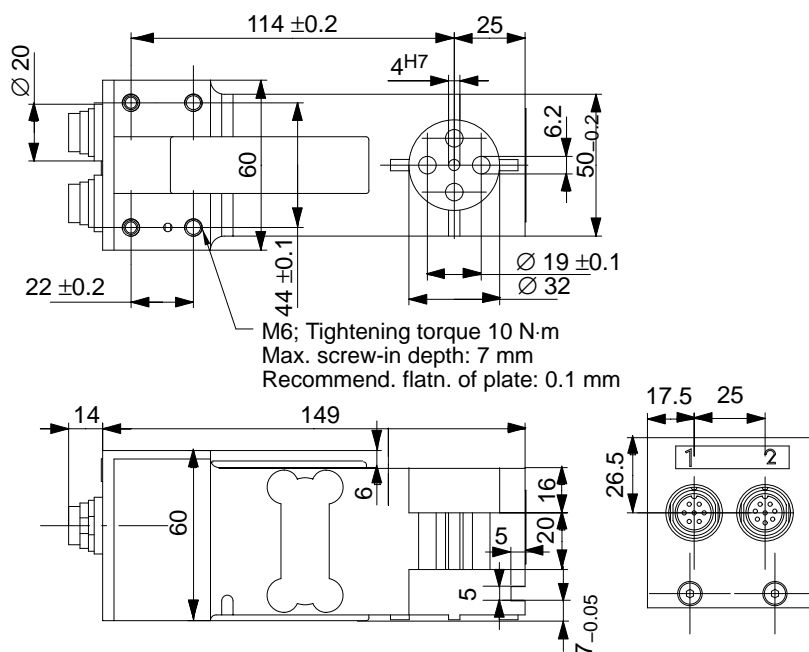

The FIT/0... digital load cell is available in different versions, e.g.:

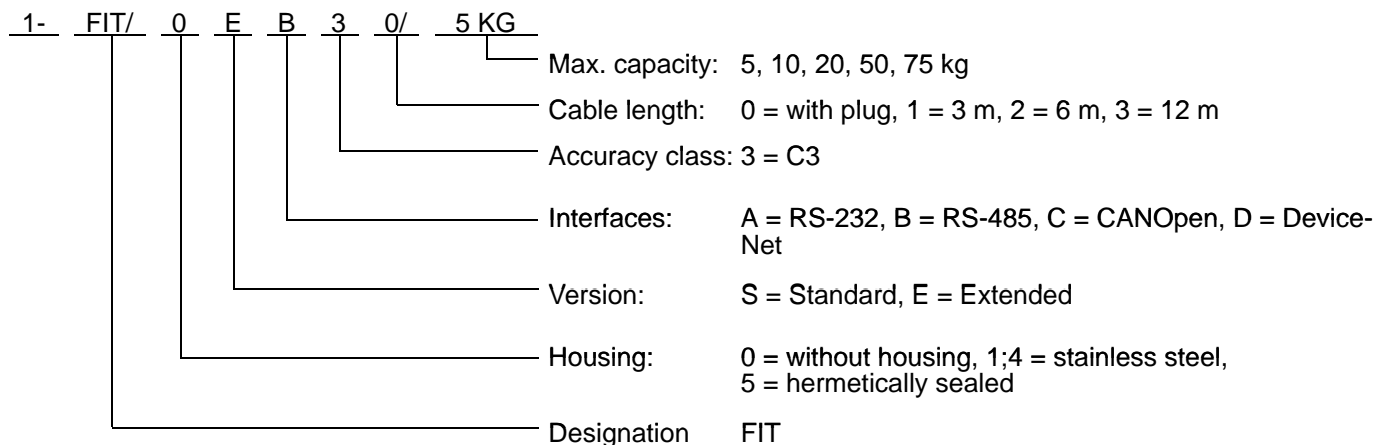

HBM has defined so-called preferred variants.

All other variants are available on request.

Preferred variants of the standard types

Housing	Interface			
	RS-232	RS-485 (4 wire)	CANOpen	DeviceNet
0	–	1-FIT/0SB30/5KG 1-FIT/0SB30/20KG	1-FIT/0SC30/5KG	1-FIT/0SD30/5KG
1	1-FIT/1SA31/5KG 1-FIT/1SA31/10KG 1-FIT/1SA31/20KG	1-FIT/1SB31/5KG 1-FIT/1SB31/10KG 1-FIT/1SB31/20KG	1-FIT/1SC31/10KG	1-FIT/1SD31/10KG

Preferred variants of the extended types

In addition to the standard version (S), another extended version (E) with control functions (two connectors) is available. All versions offers additional application areas with limit values and dosing control functions (sorting systems, filling systems).

Housing	Interface			
	RS-232	RS-485 (4 wire)	CANOpen	DeviceNet
0	–	1-FIT/0EB30/5KG	1-FIT/0EC30/5KG	1-FIT/0ED30/5KG
1	1-FIT/1EA31/75KG	1-FIT/1EB31/10KG	1-FIT/1EC31/10KG	1-FIT/1ED31/10KG
4	–	1-FIT/4EB31/5KG 1-FIT/4EB32/10KG	1-FIT/4EC31/10KG	1-FIT/4ED31/10KG
5	1-FIT/5EA30/10KG	1-FIT/5EB30/5KG 1-FIT/5EB30/10KG	1-FIT/5EC30/5KG 1-FIT/5EC30/10KG	1-FIT/5ED30/5KG 1-FIT/5ED30/10KG 1-FIT/5SC30/10KG

 = for these load cell types separate data sheets are available

Specifications

Type		FIT/0...				
Accuracy class according to OIML R60		C3				
Max. capacity (E_{max})	kg	5	10	20	50	75
Min. load cell verification interval (v_{min})	g	0.5	1	2	5	10
Min. application range for 3000 d	kg	1.5	3	6	15	30
Max. platform size	mm	L 400 x W 400			L 600 x W 500	
Max. number of load cell verification intervals (n_{LC})		3000				
Apportionment factor (p_{LC})		1				
Temperature effect on sensitivity (TK_C) ^{1) 2)} in temperature range 0°C...+40°C	% / 10K	±0.0250				
Temperature effect on zero signal (TK_{S0}) ²⁾	% / 10K	±0.0200				
Hysteresis factor (d_{hy}) ^{1) 2)}	%	±0.0166				
Nonlinearity (d_{lin}) ^{1) 2)}	%	±0.0166				
Creep (d_{CR}) over 30 min	%	±0.0166				
Eccentric loading error acc. to OIML R76	%	±0.0233				
Service load (E_U); max. 120 mm eccentricity	% E_{max}	150				
Safe load limit (E_L); max. 20 mm eccentricity	% E_{max}	300 (without overload protection)				
Permissible dyn. load (F_{srel}); max. 50 mm eccentricity	% E_{max}	70				
Deflection at max. capacity (s_{nom})	mm	< 0.2				
Power supply:						
Supply voltage UB1 (DC)	V	+ 10 ... +30				
Power consumption	W	≤ 2				
Switch-on current	A	0.2				
Resolution of meas. signal (1 Hz-Filter)	Bit	20				
Measuring rate	1/s	4 ... 1200				
Adjustable cut-off frequency of the digital filters:						
Filtermode 0	Hz	200 ... 0.25				
Filtermode 1 (response time 62 ... 365 ms)	Hz	18 ... 2.5				
Baud rate (RS-232-, RS-485-interface)	Baud	1200; 2400; 4800; 9600; 19200; 38400; 57600; 115200				
Max. number of bus members		90				
CANOpen interface		Standard CiA DS301				
Baud rate	Baud	10 000 ... 1 000 000				
DeviceNet interface		Release 2.0 ODVA				
Baud rate	Baud	125 000 ... 500 000				
max. cable length (CANOpen, DeviceNet)	m	≤ 5000 (10KBaud)... ≤ 100 (500KBaud), ≤ 25 (1MBaud)				
Diagnostic channel, RS-485-2-wire (version E)						
Baud rate	Baud	38 400				
max. cable length	m	500				
Max. number of bus members		90				
Asynchronous serial interface (Plug 1)						
RS-485, 4 wire, max. cable length	m	500				
RS-232 max. cable length	m	15				
Trigger input (plug 1)						
Permissible input voltage	V	0 ... +12				
Low-level	V	< 1				
High-level	V	> 4				
Input resistance	kΩ	10				
Control inputs (optional, plug 2)		isolated, reference potential GND2				
Permissible input voltage	V	0 ... +30				
Low-level	V	< 6				
High-level	V	> 10				
Input resistance	kΩ	> 3				
Control outputs (optional, plug 2)		isolated, reference potential GND2				
External supply voltage UB2	V	+11 ... +30				
Max. current of one output	A	< 0.5				
Accumulated current of all outputs	A	< 1.0				
Voltage drop	V	< 1				

1) The values can be exceeded in individual cases. The resulting errors of TK_C , nonlinearity and hysteresis don't exceed the maximum permissible errors of OIML R 60 with $p_{LC} = 1$.

2) All relative errors are related to the output signal at max. capacity.

Specifications (continuation)

Nominal temperature range	°C [°F]	-10 ... +40 [+14 ... +104]
Operating temperature range	°C [°F]	-10 ... +50 [+14 ... +122]
Storage temperature range	°C [°F]	-25 ... +75 [-13 ... +167]
EMC-requirements		EN 45501, OIML R76 EN 61326-1/Tab. 4, equipment of class B EN 61326/A1, Tab. A1, equipment in industrial areas
Degree of protection acc. to EN 60529		IP 67
Connector		Binder connector, series 423, 8-pole
Material, Housing		Aluminum
Diaphragm		Silicone R830
Weight, approx.	kg	1.5

Wiring assignment

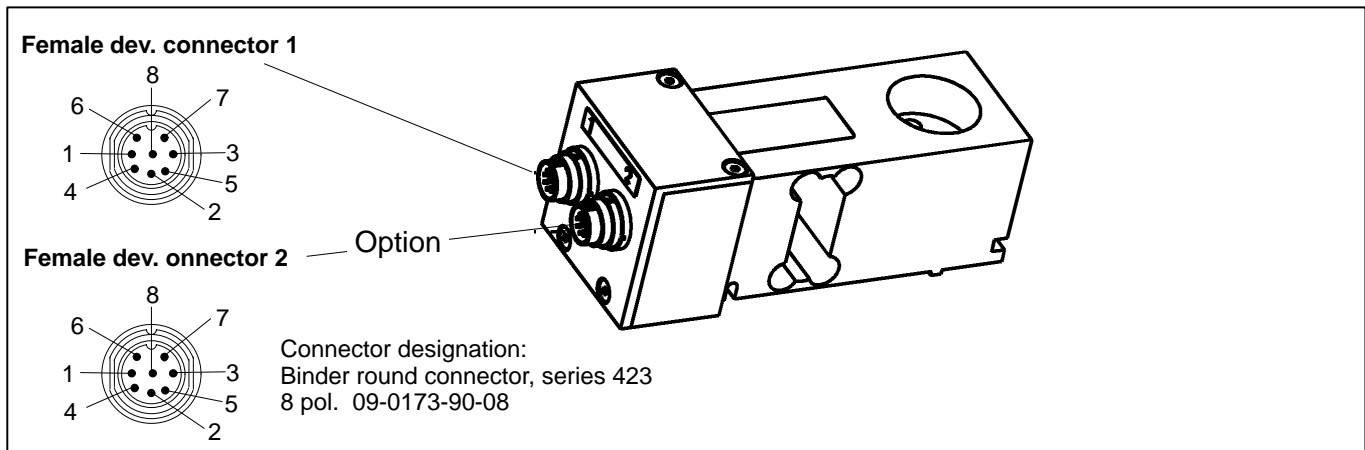

Female device connector1				Female device connector 2 (optional)	
Pin-No.	RS-232	RS-485	CANOpen/DeviceNet	Pin-No.	
8 ¹⁾	Diagnostic Rb/Tb	Diagnostic Rb/Tb	Diagnostic /Rb/Tb	8	IN 2
7 ¹⁾	Diagnostic Ra/Ta or Trigger	Diagnostic Ra/Ta or Trigger	Diagnostic Ra/Ta or Trigger	7	IN 1
4	-	RB	CanL in	4	OUT 4
3	-	TB	CanL out	3	OUT 3
2	RxD	RA	CanH in	2	OUT 2
1	TxD	TA	CanH out	1	OUT 1
6	GND1	GND1	GND 1	6	GND 2
5	+UB 1	+UB 1	+UB 1	5	UB 2

¹⁾ The standard version (S) does not have a diagnostic channel. Pin 8 not assigned, Pin 7 is trigger input

Accessories, to be ordered separately

Connection cable

Material: TPE, $\varnothing 7 \pm 0,5$ mm, Connector / free cable ends

Cable (8 cores)	1-Kab148-3 ¹⁾	1-KAB148-6 ¹⁾	1-KAB148-12 ¹⁾
-----------------	--------------------------	--------------------------	---------------------------

¹⁾ The cable is suitable only for experimental purposes for the structure of CANOpen and DeviceNet bus systems (the characteristic wave impedance does not correspond to the CANOpen specifications)

1-FIT-AED-DOC = Documentation (CD-ROM with Operating manual and AED-Panel program AED_Panel32)

- Documentation of mechanics and electronics
- Documentation of command codes for the communication with the FIT/0... load cell
- Software package for parameter setting and dynamic analysis of the weighing system

Modifications reserved.

All details describe our products in general form only. They are not to be understood as express warranty and do not constitute any liability whatsoever.

Hottinger Baldwin Messtechnik GmbH

Im Tiefen See 45, D-64293 Darmstadt, Germany

Tel.: +49 6151 803-0 Fax: +49 6151 803 9100

Email: support@hbm.com Internet: www.hbm.com



measurement with confidence